



## ND45 - POWER NETWORK ANALYZER / RECORDER

- Measurement and recording of over 500 electric energy quality parameters acc. to EN 50160, EN 61000-4-30, EN 61000-4-7 standards.
- **Measuring class A** - for 3 second aggregation **Urms, Irms**. 10 minute and 2 hour aggregation - class S.
- Operation in 3 or 4-wire, 3-phase, balanced or unbalanced power networks.
- Analysis of current and voltage harmonics and interharmonics up to the 51 st for class I (acc. to EN 61000-4-7).
- Flicker.
- 4-quadrant energy measurement in **4 tariffs**.
- **Monitoring up to 6 additional energy meters with pulse output.**
- **Recording of measurements before and after events (dips & swells).**
- Configurable archives of actual values and events recording.
- Data archiving on an SD card - memory up to 32 GB.
- E-mail messages in case of alarm occurs,
- Web server (HTTP protocol), FTP server, DHCP client.
- Interfaces: **RS-485 Modbus Slave**, Ethernet 100 Base-T (Modbus TCP/IP), USB Device & Host.
- Colour touch screen: LCD TFT 5.6", 640 x 480 pixels.
- IP65 protection grade from the frontal side.
- Synchronization of RTC clock with the NTP time server.



\* for selected parameters - details in the technical data

### EXAMPLE OF APPLICATION

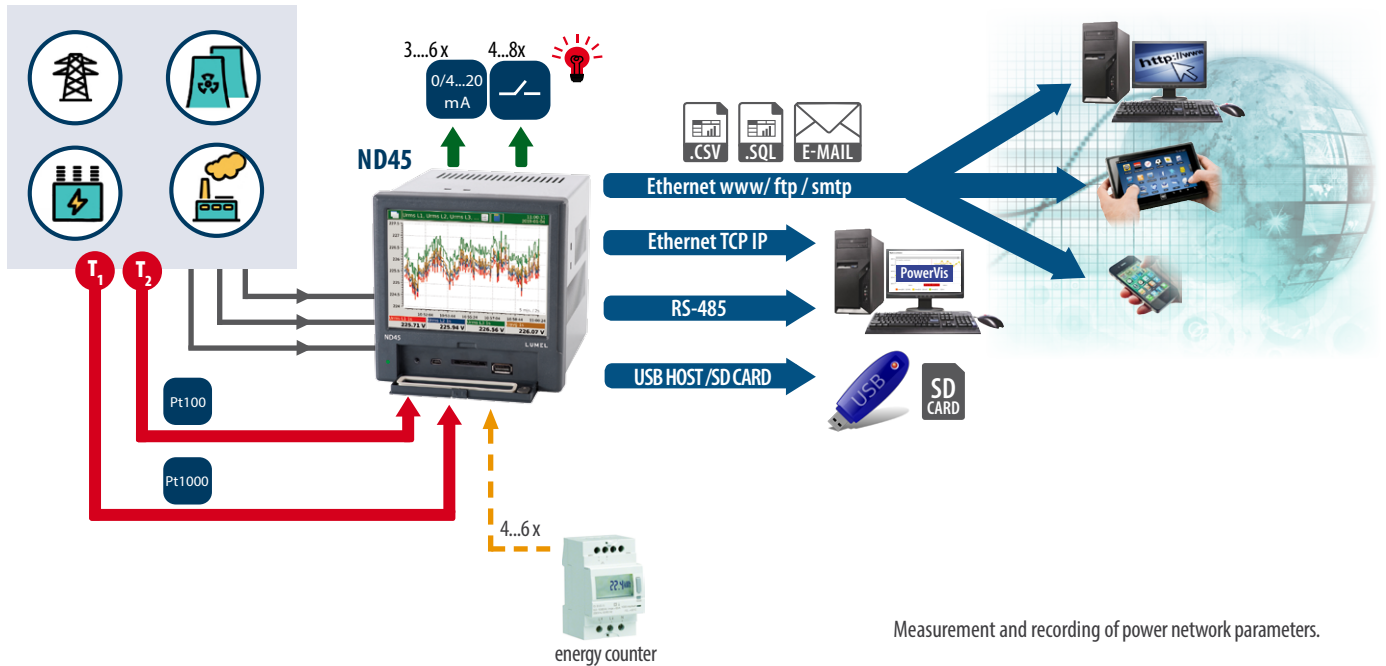

Measurement and recording of power network parameters.

# ND45 - POWER NETWORK ANALYZER / RECORDER

## MEASUREMENT AND VISUALIZATION OF POWER NETWORK PARAMETERS

### Aggregated values for 3 seconds, 10 minutes and two hours:

- phase voltages  $U_1, U_2, U_3, U_{123, avg}$
- phase current  $I_1, I_2, I_3, I_{123, avg}$
- active phase powers  $P_1, P_2, P_3, \Sigma P_{123}, P_{123, avg}$
- reactive phase powers  $Q_1, Q_2, Q_3, \Sigma Q_{123}, Q_{123, avg}$
- apparent phase powers  $S_1, S_2, S_3, \Sigma S_{123}, S_{123, avg}$
- active power factors  $PF_1, PF_2, PF_3, PF_{123, avg}$
- power factor distortion  $dPF_1, dPF_2, dPF_3, dPF_{123, avg}$
- reactive/active power factors  $tg\phi_1, tg\phi_2, tg\phi_3, tg\phi_{123, avg}$
- phase-to-phase voltages  $U_{12}, U_{31}, U_{23}, U_{123, avg}$
- current in neutral wire  $I_n$
- the angle between the voltage and current  $\phi_1, \phi_2, \phi_3, \phi_1, \phi_{123, avg}$  (degrees and radians)
- voltage phase-to-phase angle  $\sphericalangle U_{12}, \sphericalangle U_{31}, \sphericalangle U_{23}, \sphericalangle U_{123, avg}$

### Other parameters:

- frequency (aggregation for 1 and 10 seconds)
- temperature/ resistance values (two channels)
- Demand values: P, Q, S, U, I (15-minute, 30-minute or 1 hour).
- energy: active imported/exported, reactive imported/exported and apparent. All energies are calculated for each phase and 3-phase parameters.
- factors: THD, THDS, THDG, PWH. Calculated for currents and voltages of each phase and 3-phase parameters.
- harmonics from 1 up to 51st for each phase of currents and voltages
- interharmonics from 1 up to 51st for each phase of currents and voltages
- the half wave voltage of each phase
- recording of dips, swells and overvoltages
- storage of minimum and maximum of measured values.

### FEATURES

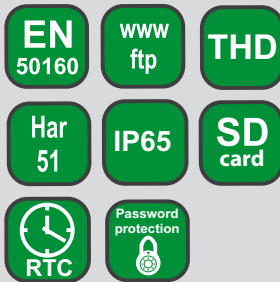

### INPUTS

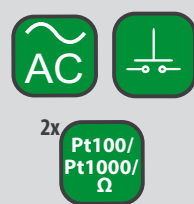

### OUTPUTS

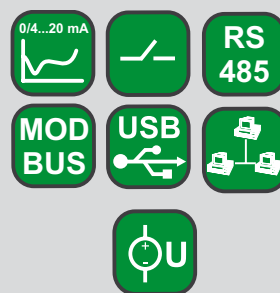

### GALVANIC ISOLATION

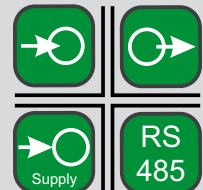

## TECHNICAL DATA

### INPUTS

Input type	Measuring range	Parameters	Basic error
Voltage input	230/400 V   57,7/100V	69.3/ 120 V	± 0.1%
Current input	1 A or 5A		± 0.1%
Logic input	4 or 6 logic inputs: 0/5...24 V d.c.	switching frequency up to 50 Hz	
Input for temperature measurement	2 inputs: Pt100 (-200...850°C) lub Pt1000 (-200...850°C) , resistance: 0...5000 Ω		± 0.2%

### OUTPUTS

Output type	Properties
Analog output	3 or 6 programmable current outputs 0/4...20 mA, load resistance < 500 Ω
Relay output	4 or 8 programmable electromagnetic relays, voltageless NO contacts, load capacity 250 V a.c./1 A a.c.

### DIGITAL INTERFACES

Interface type	Properties
RS-485	interface: Modbus Slave, baud rate 300...115200 bit/s, transmission mode ASCII/RTU
USB	2 interfaces: Device & Host, USB v.2.0
Ethernet	100 Base-T, RJ45 socket, Modbus TCP/IP, web server (HTTP), FTP server, DHCP client



## EXAMPLES OF MEASURING DATA PRESENTATION

### Various forms of data display:

- digital display
- analog view,
- bargraphs,
- vector diagrams
- trends
- energy meter
- harmonics analysis
- energy meter.

Screen system log files.

Screens log alarms.

Control panel.

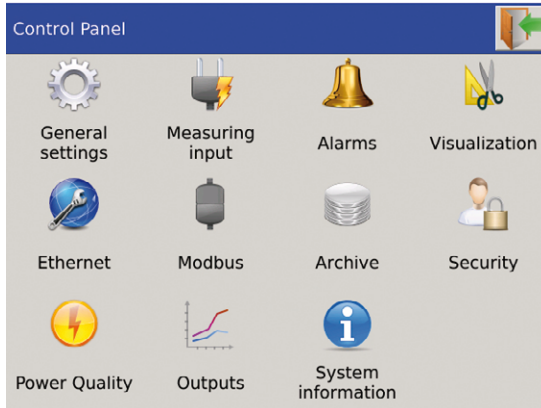

Control Panel

- General settings
- Measuring input
- Alarms
- Visualization
- Ethernet
- Modbus
- Archive
- Security
- Power Quality
- Outputs
- System information

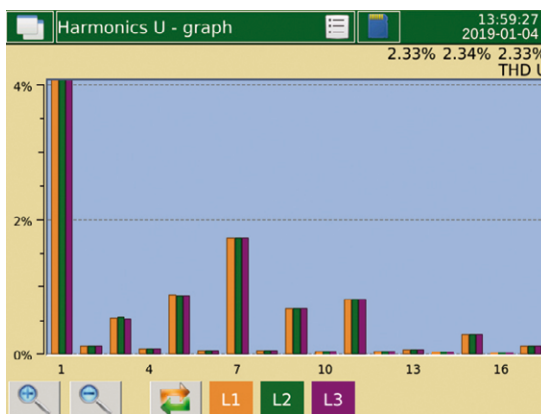
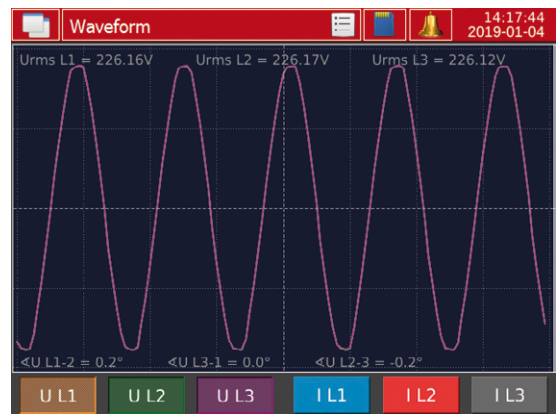
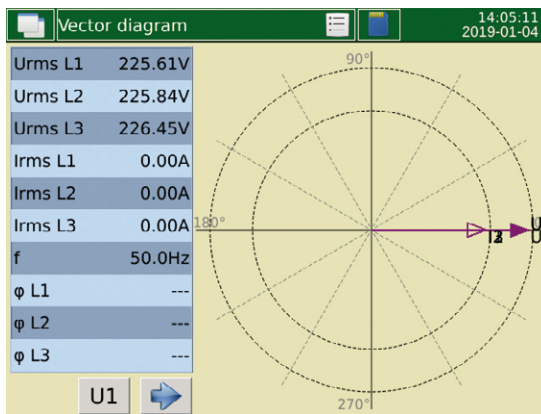
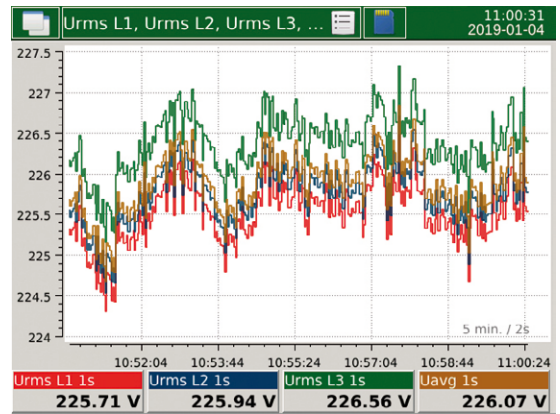
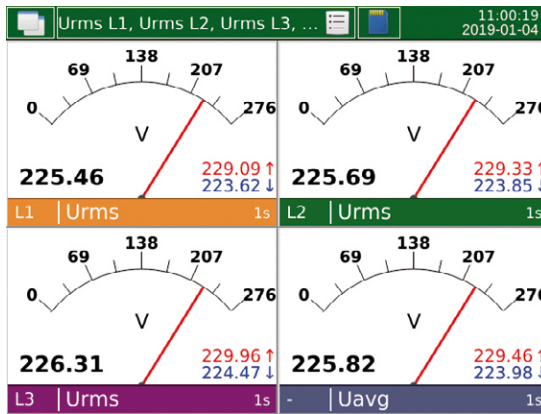
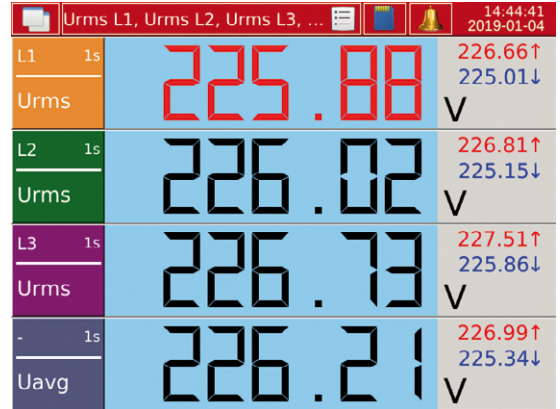
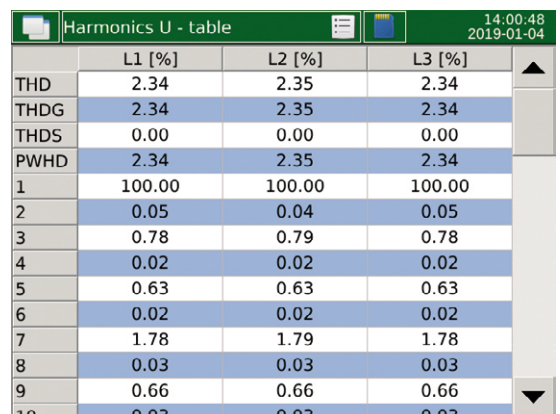







	L1 [%]	L2 [%]	L3 [%]
THD	2.34	2.35	2.34
THDG	2.34	2.35	2.34
THDS	0.00	0.00	0.00
PWHD	2.34	2.35	2.34
1	100.00	100.00	100.00
2	0.05	0.04	0.05
3	0.78	0.79	0.78
4	0.02	0.02	0.02
5	0.63	0.63	0.63
6	0.02	0.02	0.02
7	1.78	1.79	1.78
8	0.03	0.03	0.03
9	0.66	0.66	0.66
10	0.03	0.03	0.03

# ND45 - POWER NETWORK ANALYZER / RECORDER

## EXAMPLES OF MEASURING DATA PRESENTATION

Energy			13:08:41 2019-01-04
	value	unit	
Σ EnP+	00000000.0	kWh	
L1	00000000.0	kWh	
L2	00000000.0	kWh	
L3	00000000.0	kWh	
Σ EnP-	00000000.0	kWh	
L1	00000000.0	kWh	
L2	00000000.0	kWh	
L3	00000000.0	kWh	
Σ EnQ+	00000000.0	kVARh	
L1	00000000.0	kVARh	

Binary inputs				14:07:45 2019-01-04
	BI1		BI2	
	1		0	
	BI3		BI4	
	0		0	
	BI5		BI6	
	0		0	

Alarm logs				14:18:23 2019-01-04
No	Date	Time	Description	
43	2016-01-20	13:49:54	Alarm 2 - Wf. (Urms L2 200ms 224.811V) (> 210)	
42	2016-01-20	13:49:54	Alarm 1 - Wf. (Urms L1 200ms 224.823V) (> 200)	
41	2016-01-20	08:53:15	Alarm 1 - Wf. (Urms L1 200ms 240.477V) (> 200)	
40	2016-01-19	16:00:19	Alarm 2 - Wf. (Urms L2 200ms 229.91V) (> 210)	
39	2016-01-19	16:00:19	Alarm 1 - Wf. (Urms L1 200ms 229.898V) (> 200)	
38	2016-01-19	15:36:32	Alarm 2 - Wf. (Urms L2 200ms 228.824V) (> 210)	
37	2016-01-19	15:36:31	Alarm 1 - Wf. (Urms L1 200ms 228.798V) (> 200)	

## ETHERNET: WWW SERVER, FTP

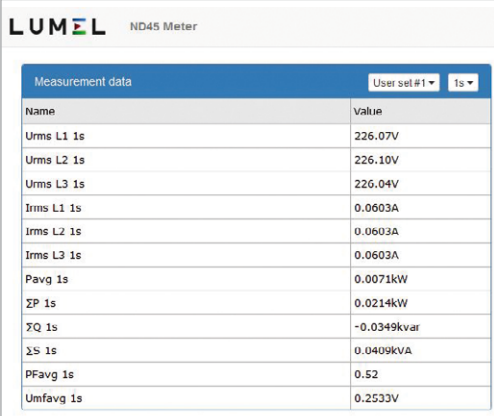

Name	Value
Urms L1 1s	226.07V
Urms L2 1s	226.10V
Urms L3 1s	226.04V
Irms L1 1s	0.0603A
Irms L2 1s	0.0603A
Irms L3 1s	0.0603A
Pavg 1s	0.0071kW
ΣP 1s	0.0214kW
ΣQ 1s	-0.0349kvar
ΣS 1s	0.0409kVA
PFavg 1s	0.52
Umfavg 1s	0.2533V

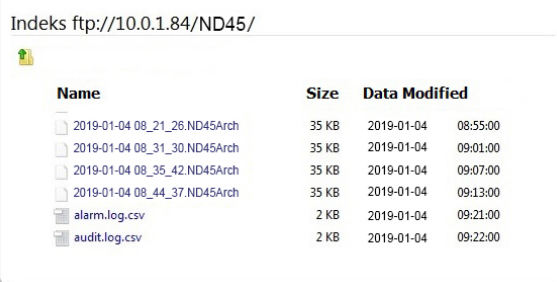

Name	Size	Data Modified
2019-01-04_08_21_26.ND45Arch	35 KB	2019-01-04 08:55:00
2019-01-04_08_31_30.ND45Arch	35 KB	2019-01-04 09:01:00
2019-01-04_08_35_42.ND45Arch	35 KB	2019-01-04 09:07:00
2019-01-04_08_44_37.ND45Arch	35 KB	2019-01-04 09:13:00
alarm.log.csv	2 KB	2019-01-04 09:21:00
audit.log.csv	2 KB	2019-01-04 09:22:00

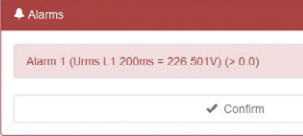

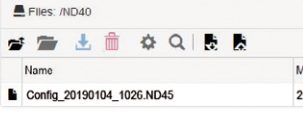

Alarm 1 (Urms L1 200ms = 226.501V) (> 0.0)

Confirm



Name	Modified	Size
Config_20190104_1026.ND45	2019-01-04 10:26:39	10.7 kB



Field	Value
Device name	ND45
Device description	Power Analyzer
Serial number	16010002
System version	0.2.11
Used space on SD card	

# ND45 - POWER NETWORK ANALYZER / RECORDER

## DIMENSIONS AND ASSEMBLY

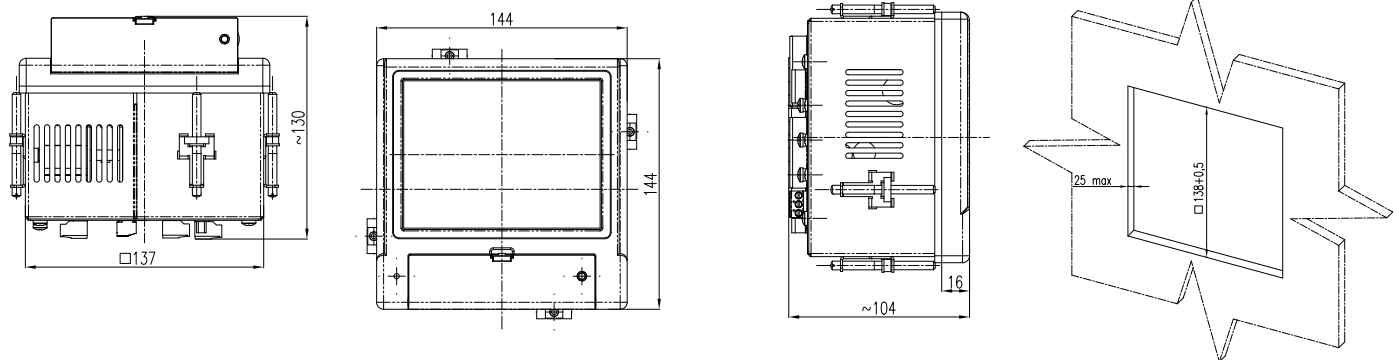

## ORDERING CODE

Power network analyzer ND45	X	X	X	X	X	XX	X
<b>Input voltage (phase/phase-to-phase) Un:</b>							
3 x 57.7/100 V	1						
3 x 230/400 V	2						
3 x 69.3/120 V	3						
<b>Inputs/ Outputs:</b>							
whitout		0					
8 relay outputs		1					
6 logic inputs, 4 relay outputs		2					
6 logic inputs, 3 outputs 0/4-20 mA		3					
4 logic inputs, 6 outputs 0/4-20 mA		4					
<b>Supply:</b>							
85...253 V a.c., 90...300 V d.c.			1				
<b>Measuring class:</b>							
S class				0			
A/S class				1			
<b>Language:</b>							
Polish					P		
English						E	
<b>Version:</b>							
standard						00	
in a portable casing						01	
custom-made*						XX	
<b>Acceptance tests:</b>							
without additional quality requirements							0
with an extra quality inspection certificate							1
with an extra calibration certificate							2
acc.to customer's request							X

### IN STANDARD:

- two temperature inputs Pt100 or Pt1000,
- RS-485 Modbus Slave,
- Ethernet.

### ORDER EXAMPLE:

The code: **ND45 1 2 1 0 E 00 1** means:

**ND45** - power network analyzer ND45 type

**1** - input voltage 3 x 57,7/ 100 V

**2** - 6 logic inputs, 4 relay outputs

**1** - supply 85...253 V a.c., 90...300 V d.c.

**0** - S measuring class

**E** - english version

**00** - standard version

**1** -with an extra quality inspection certificate.

\* only after agreeing with the manufacturer

**Sifam Tinsley Instrumentation Inc.**

**Address:** 2105 Barrett Park Dr, Unit 105, Kennesaw, GA 30144

**Tel.:** 800-879-6171 | **E-mail:** info@sifamtinsley.com | **Web:** www.sifamtinsley.com